

SIMPLE SOLUTIONS: ERGONOMICS FOR FARM WORKERS

Edited By:

Sherry Baron¹
Cheryl F. Estill²
Andrea Steege¹
Nina Lalich¹

U.S. DEPARTMENT OF HEALTH AND HUMAN SERVICES
Public Health Service, Centers for Disease Control and Prevention
National Institute for Occupational Safety and Health

¹Division of Surveillance, Hazard Evaluations, and Field Studies

²Division of Applied Research and Technology

February 2001

Disclaimer: Mention of any company or product does not constitute endorsement by NIOSH.

Cover photo printed with permission. Private citizens and companies must obtain permission to reproduce this photo.

Excluding the cover photo, all other information in this booklet is in the public domain and may be freely copied or reprinted.

Ordering Information

To receive documents or other information about occupational safety and health, contact the National Institute for Occupational Safety and Health (NIOSH) at

NIOSH Publications Dissemination
4676 Columbia Parkway
Cincinnati, OH 45226-1998

Fax: 513-533-8573
Telephone: 1-800-35-NIOSH
(1-800-356-4674)

E-mail: pubstaft@cdc.gov

or visit the NIOSH web site at www.cdc.gov/niosh

DHHS (NIOSH) Publication No. 2001-111

Simple Solutions: Ergonomics for Farm Workers

Summary

- Backaches and pain in the shoulders, arms, and hands are the most common symptoms that farm workers report.
- These injuries can be disabling, which can affect the worker's earnings and the grower's profits.
- There are cost-effective ways to prevent or reduce these symptoms.
- The “tip sheets” in this booklet show how to make or order inexpensive new tools or to modify existing ones to reduce the risk of pain.
- Solutions discovered for one type of crop can be modified for use with other kinds of crops.
- Worker-management ergonomics teams can be formed to discover your own simple solutions.



Newly designed stands for potting plants. The stands hold the plant bins at an angle. The slope lets gravity move the plants to the front of the bin so that the plants are always close to the worker and reaching is minimized.

Acknowledgments

We wish to thank those who helped with the production of this booklet:

Writer-Editor: Jane Slaughter

Graphic design and production: Jim West

Cover photo: David Bacon

Illustrations: Mike Konopacki (Huck/Konopacki Labor Cartoons, Madison, Wisconsin); Dan Watkins, Don Murdock, Richard Carlson (NIOSH, Cincinnati, Ohio).

Focus group participants in San Luis Obispo, California, and for organizational help James Meyers, Kimberly Naffziger, and Richard Caveletto.

Focus group participants in Sparta, Michigan, and for organizational help Manny Gonzalez and Jan Tijerina.

Simple Solutions: Ergonomics for Farm Workers

Oh, My Aching Back!	1
What is Ergonomics?	3
Ergonomic Rules of Thumb	5
Cheryl F. Estill	
Tip Sheets	8
Lifting Tool for Carrying Plant Containers	9
James Meyers, John Miles, Victor Duraj, Julia Faucett, Ira Janowitz, Diana Tejada, Araceli Suriano, Lynn Bloomberg	
Weeding Stand for Plant Nurseries	11
James Meyers, John Miles, Victor Duraj, Diana Tejada, Julia Faucett, Ira Janowitz, Araceli Suriano	
Smaller Picking Tub	13
James Meyers, John Miles, Victor Duraj, Diana Tejada, Julia Faucett, Ira Janowitz, Araceli Suriano	
A Specialized Harvest Cart for Greens	15
Bob Meyer, Astrid Newenhouse, Marcia Miquelon, Larry Chapman	
Participatory Ergonomics Team	17
Ninica L. Howard	
New Rakes for Harvesting Berries	19
Cheryl F. Estill, Shiro Tanaka, Deanna K. Wild	
Power Cutter for Woody Plants	21
James Meyers, John Miles, Sayedahmad Shafii, Victor Duraj, Diana Tejada, Julia Faucett, Ira Janowitz, Araceli Suriano	
Metered Liquid Applicator	23
James Meyers, Victor Duraj, John Miles, Diana Tejada, Julia Faucett, Ira Janowitz, Araceli Suriano	
A Rolling Dibble Marker for Easy Transplant Spacing	25
Bob Meyer, Astrid Newenhouse, Marcia Miquelon, Larry Chapman	

Scraper Handle27
Ninica L. Howard	
Simple Solutions Are Cost-Effective28
Mesh Bags: Easy Batch Processing29
Bob Meyer, Astrid Newenhouse, Larry Chapman	
Standard Containers31
Astrid Newenhouse, Bob Meyer, Larry Chapman	
Narrow Pallet System33
Bob Meyer, Astrid Newenhouse, Larry Chapman	
Packing Shed Layout35
Astrid Newenhouse, Bob Meyer, Larry Chapman	
Written Materials for Farm Workers37
Tips for a Healthy Back38
Michael E. Samuels, Eben Howard, E. Roberta Ryder, Joni Berardino, Madge Vásquez, Larisa Ludeke, Linda Lopez	
Company Safety Director Testifies: 'Ergonomics Works!'40
Alethea Leandro	
Resources: Videos, Pamphlets, Consultation Services42

Oh, My Aching Back!

Farm work is hard work, and farm workers feel the results. Farm workers get backaches and pains in the shoulders, arms, and hands more than any other health problem. A third of the injuries that cause them to miss work are sprains and strains, and a quarter are back injuries. These are also the most common causes of disability.

The technical term for these sprains and strains is “work-related musculoskeletal disorders” (WMSDs). WMSDs hurt! They hurt:

- workers’ bodies
- workers’ earnings
- growers’ profits.

In California agriculture alone, the annual workers’ compensation costs for the more than 3,000 back injuries that happen each year may be over \$22 million.

This pamphlet is about early intervention to prevent such injuries. It is directed toward growers, safety specialists, human resources managers—anyone with an interest in having safe farms.

Over the years, many kinds of farm work have not changed much at all. Field work is still done in a stooped position. Workers carry heavy weights in awkward positions, kneel often, work with their arms above shoulder level, or move their hands and wrists repetitively. Sometimes the whole body is subject to vibration from farm equipment. When workers are paid on piece rate, they have a reason to keep up a rapid, sustained pace. Overexertion intensifies all the other risk factors.

Many people in the farm industry may believe that these kinds of tasks—and the resulting sprains and strains—are just an unavoidable part of farm work. But NIOSH (National Institute for Occupational Safety and Health) asked university researchers, specialists in the science of ergonomics, to look into how farm work could be made safer. They worked with growers and employees on different types of farms to come up with some simple, practical, inexpensive solutions. This pamphlet is a result of that hands-on cooperation.

NIOSH believes that better work practices and tools will reduce the sprains and strains of farm work.

As you read this pamphlet, the specific solutions may or may not apply to your particular operation. But we think you'll learn three things from it anyway:

**These
suggestions
can be
adapted
for your
own
farm.**

- what sorts of work are most likely to cause injuries
- basic ergonomic rules of thumb for working more safely
- inspiration to sit down with employees and come up with some simple solutions of your own

The ideas in this pamphlet can be adapted for many types of crops and for different sizes of farm operation.

Don't get discouraged if some solutions seem out of reach. A small tool change or adjustment in the work layout can make a big difference in preventing injuries. Good luck!

What Is Ergonomics?

The goal of the science of ergonomics is to find a best fit between worker and job conditions. Ergonomics looks at:

- the physical capabilities of the human body
- the limitations of the human body

in relation to

- a person's work tasks
- tools used
- the job environment

The goal is to make sure workers are uninjured, safe, and comfortable, as well as productive.

Work-related musculoskeletal disorders (WMSDs) are:

- the leading cause of disability for people in their working years
- caused by chronic exposure to these physical stresses
 - forceful gripping
 - kneeling
 - lifting
 - squatting
 - bending
 - vibrating equipment
 - twisting

Ergonomics finds the best fit between worker and job.

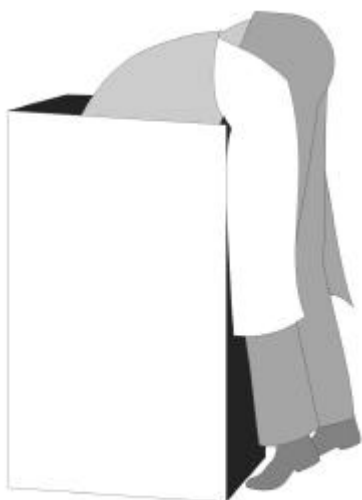

Bending



Twisting

The best way to reduce WMSDs is:

- redesign the tools
 - redesign how the work process is done
- } using the principles of ergonomics

Relatively simple changes can make a big difference. When jobs and tools are ergonomically redesigned, you don't have to rely on a carrot or a stick to get people to work safely. Injuries are prevented as a natural result of improved work posture, reduced force, or less repetition. Ergonomic changes should be put into operation along with worker training on how to work safely.

How Do I Know if I Need an Ergonomics Program?

- Do some jobs cause strain, localized fatigue, discomfort, or pain that does not go away after an overnight rest?
- Do injury records or workers' compensation claims show hand, arm, or shoulder pain, low back pain, or carpal tunnel syndrome?
- Do workers visiting the clinic make frequent references to physical aches and pains related to certain types of work assignments?
- Do jobs involve repetitive and forceful exertions, frequent heavy or overhead lifts, awkward work positions, or use of vibrating equipment?
- Are cases of WMSDs found among competitors or in similar businesses?
- Do trade publications or employers' insurance information indicate risk of WMSDs?

Ergonomic Rules of Thumb

Strains and sprains are caused by excessive reaching, bending, lifting, gripping, squatting, or twisting of hands, shoulders, or body. In general, any work performed with high force, with many repetitions, or in a position that feels awkward is risky. Even a motion that is harmless in and of itself, like stretching out the arm to grasp an object, or squeezing a tool, may put the worker at risk of injury if it is repeated over and over.

Following these guidelines will reduce the chance of sprains and strains. You may need to reposition the work, or redesign the way the job is done, or use a different tool.

⇒ **Remember: You may not be able to implement all the changes recommended here. But even partial changes or small changes can reduce injuries.**

Guidelines for Hand Work

- Avoid placing needed tools or other items above shoulder height.

- Position items that are used often within 17 inches of the worker.

- When movements are repeated over and over, as in picking or weeding, allow enough time in between for adequate recovery, by having the worker alternate with a low-repetition task. For example, a worker who performs a high-repetition weeding task should be given other tasks that don't require repetitive hand motions, like carrying the finished boxes to the loading area.

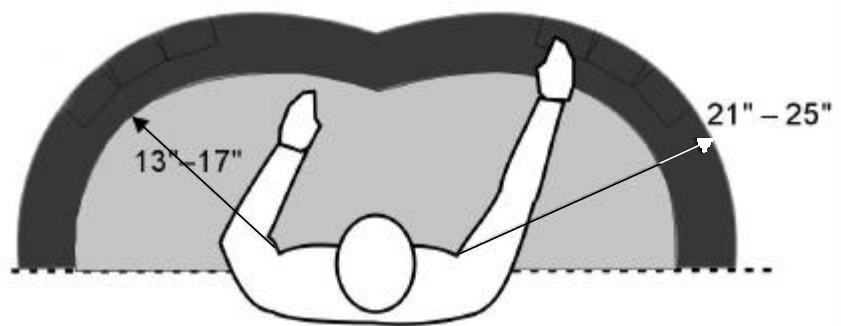

Primary  and secondary  areas for table top work.

Position items that are used often close to the worker.

- Provide seated jobs. Sitting down while working reduces the strain on the lower back and legs. Standing causes legs to swell (more than walking does). The best jobs are ones that allow workers to do different types of work, changing from sitting to standing to walking and back again.
- Allow foot and knee clearances for both standing and sitting workers, so they can get close to the work.

- Provide floor mats for standing work stations, to reduce fatigue.
- For standing work, use the proper work station height.

Guidelines for Hand Tools

- When tools require force, handle size should allow the worker to grip all the way around the handle so that the forefinger and thumb overlap by 3/8". Handle diameter should range from 1-3/8" for small hands to 2-1/8" for large hands, with an average of 1-3/4".



Handle diameter is large enough for small overlap of thumb and fingers.

- Handles should be covered with smooth, slip-resistant material (plastic or rubber). Dual-handed tools (like shears or pliers) should have a handle length of at least 4" and preferably 5". They should have a spring return to maintain an open position, and handles that are almost straight without finger grooves.

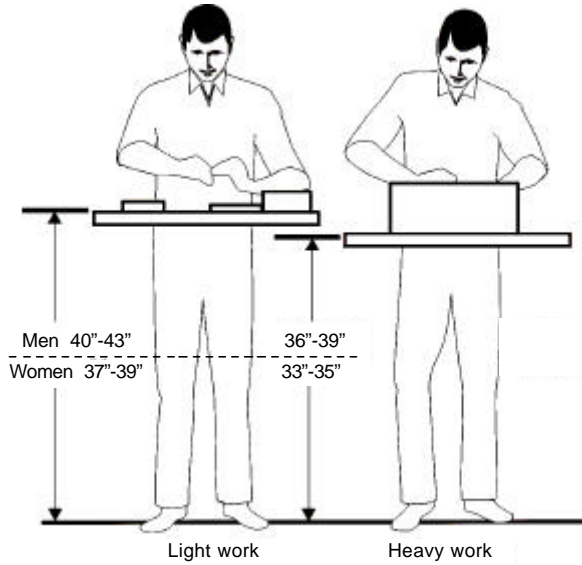

Proper work station height for light and heavy work.

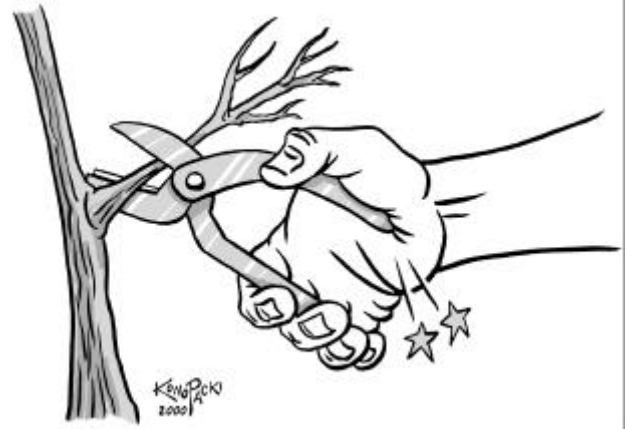

Poorly-designed tool: Handle presses into base of palm and requires user to open after each cut (no spring).

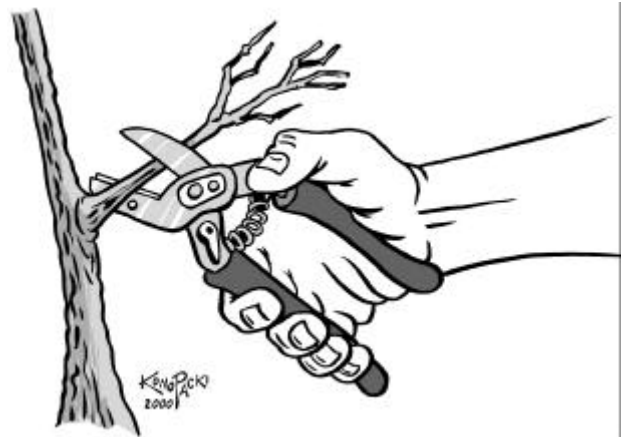

Well-designed tool: Handles are long. Spring return keeps tool open. Handles are covered with rubber or plastic grip.

Guidelines for Lifting

- Keep lifts between hand level and shoulder level. Avoid lifts from the floor or over shoulder level.
- Provide handles on containers.
- Redesign loads so they can be lifted close to the body.
- Provide dollies, pallet trucks, or utility carts for objects that have to be carried more than a few feet. Provide roller conveyors for bags or boxes of vegetables or chemicals that are handled often. This will reduce the amount of lifting.



Lifting from a good height, between waist and shoulder level.

- Keep bag or box weight below 50 lbs. Or use the NIOSH Lifting Equation to determine an acceptable weight. See the Resources section for information on the Lifting Equation.

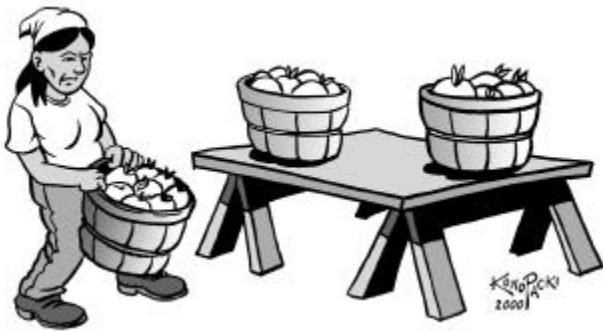

Poorly-designed load: No handles, and load must be carried too far from the body.



Better-designed load: Handles are provided and the load is closer to the body.

Guidelines for Stooped Work

- Redesign the job to avoid stooped work:

Attach long handles to tools. (For an example, see pages 9-10.)

Provide stools. (For an example, see pages 15-16.)

- If stooped work is required, provide employees with other short tasks that require walking or sitting.

Tip Sheets

The following 28 pages show some simple ergonomic solutions that farms have tried out. Some show new or adapted tools that were invented to make work safer or easier. Others show more efficient ways to do the work. Sometimes the solutions reduce the time needed to perform an operation. The basic rule is that the solutions (a) should not cost much in relation to the benefit achieved, and, if possible, should result in quick savings, and (b) should reduce injuries.

As you look through these tip sheets, try not to concentrate on whether they refer directly to your type of crop. Most of the ideas are adaptable for use on many different types of farms. They're also meant to stimulate your creativity to think up your own simple solutions. Or, as described on pages 17-18, you can get your employees brainstorming about ideas that will work in your operation.

Lifting Tool for Carrying Plant Containers

Problem:

Lifting and carrying plant containers by hand can cause injuries.



- Worker must stoop, grip, and lift repeatedly.
- Forward stooping can contribute to lower-back injury.
- Finger-pinch gripping can lead to tendinitis in hands.

One Solution:

Use specially designed handles to pick up and carry containers.



- Tool handle allows a full-hand “power grip” rather than a pinch grip.
- Decreases forward bending angle and amount of time spent in stooped posture.
- Reduces lifting strain.
- Can improve worker productivity.

Tips for Use of Tool:

The tool is designed to allow the container to swing back and hang at a comfortable angle. Do not apply excessive wrist torque when setting container down onto a surface. Instead, allow space for a gentle forward swing that is timed with placement of the container on the surface. The back-grip design keeps hands clear of thorns on certain types of plants and allows for a straight wrist position while carrying a container. It is advisable to use two tools and carry two plants, to balance the load on the body. Avoid carrying containers heavier than about 22 pounds in each hand; this would exceed guidelines for safe lifting.

Lifting Tool

How Does the Lifting Tool Work?

The tool has three parts: a) the hand-grip, b) the container coupling, and c) the 16-inch extension. It is made of aluminum and steel and has proven to work best with 5-gallon containers that have an external lip. From a standing position the worker slides the coupling point under the container's lip and lifts.



How Much Difference Does the Lifting Tool Make?

The tool shown here was designed for use in outdoor nurseries specializing in ornamental and bedding plants. At nurseries in California where it was tested, it reduced workers' forward bending angle by as much as 47%. The time spent working at a forward-bent angle of more than 20 degrees was reduced by nearly half. Hand gripping effort was reduced by more than half. Lifting strain was reduced by 40%. Workers reported less work-related pain when using the handles, and those who had the most severe symptoms at the start reported the most improvement.

How Much Will It Cost?

Materials should cost about \$15 each plus the cost of fabrication, whether done in-house or jobbed out.

How Does Tool Use Affect Productivity?

Use of the handle resulted in the same or slightly improved productivity for ground-to-ground container spacing, its recommended use.

How to Make a Lifting Tool

Materials List & Construction Information:

1. Rubber grip; tapered from about 1-3/16" to 1-7/16" OD; to fit 1" OD tube; typically available in industrial supply catalogs.
2. 1" OD x 0.065" wall aluminum tube; cut at 21°; 4-3/4" on long side; welded at 69° angle to Part 3.
3. 1" x 1" x 1/8" x 16"-long aluminum angle; holes drilled on 1" centers and 0.5" from edge measured on 1"-wide side.
4. 1.5" x 1.5" x 0.094" x 3/8"-long steel sq. tube; welded along top joint.
5. 1" x 1" x 0.065" x 5"-long steel sq. tube; 1/4" hole drilled 2-1/2" from end and 3/8" from edge; welded to Part 9 with 2" overlap.
6. 1.5" x 1.5" x 0.094" x 3/8"-long steel sq. tube; remains loose on tube.
7. 1/4" D x 1"-long steel round; inserted into Part 5 and welded flush on the non-visible side in drawing above.
8. 1-1/2" x 1/8" steel flat bar cut at about 45° with approximate top and bottom lengths of 1" and 2-1/2", respectively; notched generally as shown in drawing above (notches are for container lips that have reinforcement ribs that may interfere with the coupling of the "point" and the container); ends bent slightly forward after welding; welded to Part 9 with 1/2" overlap.
9. 1" x 1" x 0.065" steel sq. tube; cut at 45; 4-1/2" on long side.
10. 1" x 1/8" x 9-1/2" long steel flat bar; 1/2" end-bends pointing forward; approx. 7-1/4" overall width after rolling; welded at bottom of Part 9.

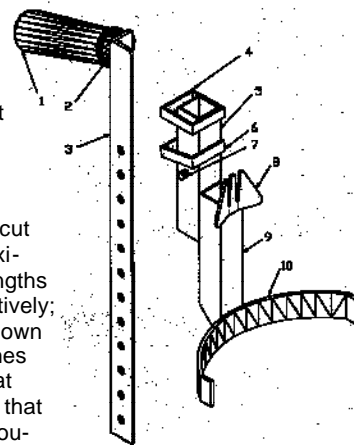

Note: Steel may be substituted for aluminum for cost or fabrication reasons, but steel will increase the tool's weight from its current 1-3/4 pounds.

Contact Information:

This Tip Sheet was produced by the University of California Agricultural Ergonomics Research Center under a grant from the National Institute for Occupational Safety and Health.

UC Ag Ergonomics Research Center, Bio & Ag Engineering, UC Davis, One Shields Avenue, Davis, CA 95616-5294. Or visit <http://ag-ergo.ucdavis.edu>.

Weeding Stand for Plant Nurseries

Problem:

When plants are kept on the ground, workers must bend completely forward to weed them, risking low-back problems.



- Newly propagated plants are often kept in plastic flats on the ground for initial growth before “potting.”
- Worker must stoop and stay in bent position to weed trays on ground.
- Worker fatigue and pain can lead to lower work quality.

One Solution:

Use a movable table to elevate trays while weeding.



- Worker can stand while weeding, relieving prolonged stress on back.
- Worker must still stoop to pick up and replace trays, but change of position is better than prolonged position.
- Tray is closer to worker, reducing strain from reaching.
- Strain reduction will improve worker performance.

Weeding Stand

Why Bother With a Table?

You can help prevent chronic back injuries among weeders and should see improved work quality.

Won't Moving the Table Slow the Worker Down?

Probably not, if you calculate productivity over the work shift. Use of the table may result in slightly slower progress while workers are fresh. By mid-day, however, when back fatigue is setting in, workers using the table will be less tired and likely to move faster.

Should I Make or Buy a Table?

Either approach is fine provided that the table is the right size to fit the workers. As pictured, the ideal table will give workers a platform for the trays at just above their waist height. It should be light enough to move easily, but sturdy enough to be stable in use.

What If Weeding Flats Is Only a Part-Time Job in My Nursery?

The weeding table is still a good investment. Lots of nursery tasks other than weeding involve stooped posture. Relief, even in a part-time job, will help prevent long-term injury and will improve worker performance.

How Can I Make a Weeding Table?

With simple materials from your facility's shop or a home improvement store. The recommended material is light-duty steel, which will hold up under wet conditions, will not be too heavy to move around, and can be welded with typical shop equipment.

The drawing on this page shows 3/4"x 3/4" x 1/8" angle iron used for the table's legs, bottom bracing, and top bracing. The tabletop could be a

piece of metal grating welded to the frame in a number of spots or a metal plate welded or bolted to the top. Cost for materials would be about \$25.

Another possibility would be to make the table of aluminum, which is lighter in weight, and bolt the parts together rather than welding them. This would require a hacksaw, drill motor, wrenches, and some additional diagonal bracing. In any case, the key elements of the stand are height and portability.



An existing table could be retrofitted, if you have access to a shop and a welder. Two of the legs could be shortened and fitted with a steel rod, two lawnmower wheels (about \$7.50 each), and push-on retaining caps, all of which are available at hardware stores.

A collapsible four-wheeled table is available ready-made for \$227.99. This table has a push handle and is 24" long x 19-3/4" wide x 30" high. Contact, for example, Materials Handling Equipment, 7433 US 30 East, Fort Wayne, IN 46803. 219-749-0475. <http://63.87.5.30/mhec/catalog.shtml>

Contact Information:

This Tip Sheet was produced by the University of California Agricultural Ergonomics Research Center under a grant from the National Institute for Occupational Safety and Health.

UC Ag Ergonomics Research Center, Bio & Ag Engineering, UC Davis, One Shields Avenue, Davis, CA 95616-5294.
Or visit <http://ag-ergo.ucdavis.edu>.

Smaller Picking Tub

Problem:

In hand harvest of wine grapes, the tubs used are heavy when full and, thus, can contribute to back and knee injuries.



- Workers cut grapes directly into plastic tubs and then carry the tubs to trailer-mounted gondolas. When full, the tubs weigh an average of 57 pounds.
- Worker must stoop, grip, lift, carry, and dump up to 20 times per hour, not including the stooping, gripping, and relocating of the tub as the worker moves down the row of vines.
- A side-sweeping motion of the leg is often used to move the tub along the vine until it is about half full, at which point the tub is lifted.
- For dumping into the gondola, the full tub is often lifted above the head.

One Solution:

Use a smaller, lighter tub (on the right) that has add-on grips and weighs an average 46 pounds when full.



- The lower weight is easier on the back, knees, and arms. The narrower width positions the tub's center of gravity closer to the worker, which reduces stress on the back.
- Lighter weight and smoother bottom surface reduce the sideways forces on the knees when pushing the tub down the row.
- Better handles reduce pressure points on the fingers.
- Can have minor negative impact on production, but has gained approval of piece-rate workers.

Picking Tub

How Much Difference Does the Smaller Tub Make?

The smaller tub was tested at several vineyards in a NIOSH-funded ergonomics study in California's Napa and Sonoma counties.

After the harvest season, workers reported pain and symptoms of injury that were only one-fifth of what they were with the large tub. Reduction of pain symptoms indicates a lower risk for future chronic injury or cumulative trauma disorder such as nagging back or joint pain.

How Does the Smaller Tub Affect Productivity?

Only negligibly. In a three-year field trial, the smaller tub resulted in a 2% reduction in pounds of grapes delivered to the gondola per day. Neither managers nor workers perceived the reduction in the field.

The reduction in productivity was not as much as might be expected, given that the two tubs are significantly different in size. This was apparently because workers using the small tub were less tired throughout the day and made 20 more carries per shift.

Despite making more carries, workers using the small tubs used less energy and had lower heart rates. They liked the smaller tubs better, reporting that they were less tired at day's end.

Here is the best "proof" that the smaller tub is better for workers: Workers on piece rate, who usually are eager for maximum productivity, preferred the smaller tub.

Where Can I Get a Smaller Tub?

The tub used in the study was a LEWISystems SN2414-8 stack/nest tub by Menasha Corporation of Watertown, Wisconsin, 800-558-9563. Cost is about \$13 each.

The SN2414-8 is two inches narrower and over two pounds lighter than the old tub. Ask your existing supplier for a smaller tub that is similar to the one used in the study; you may find good alternatives.

How Do I Make the Add-On Grips?

The add-on grips are simple to make using 1/2" PVC pipe (Schedule 40), a saw (preferably a band saw), and a jig such as suggested in the diagram below. The jig will cost about \$75 to have made.

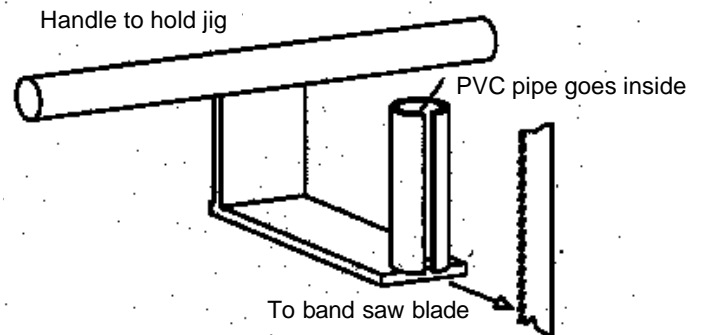

Cut the PVC pipe to 5" lengths and cut an approximately 1/32"-wide slit lengthwise in the PVC using the jig. Use a slotted screwdriver to help slide the PVC over the edge of the tub's existing grip.

Contact Information:

This Tip Sheet was produced by the University of California Agricultural Ergonomics Research Center under a grant from the National Institute for Occupational Safety and Health.

UC Ag Ergonomics Research Center, Bio & Ag Engineering, UC Davis, One Shields Avenue, Davis, CA 95616-5294.

Or visit <http://ag-ergo.ucdavis.edu>.

A Specialized Harvest Cart for Greens

Stooping or kneeling and crawling to harvest salad greens requires a lot of time and energy. Lifting and moving your harvest container many times as you fill it adds to the work load. An alternative is to build a simple cart, which allows you to sit and roll while you harvest. This is less tiring for the knees, back, hamstrings, and torso. The cart also holds your harvest container, so it rolls along with you.



How Does It Work?

The cart straddles the crop bed or rows, so that the wheels are on the paths between the beds. A seat is mounted low to the ground, between the rear wheels, allowing you to work directly over the bed without stooping. The seat swivels so you can harvest all parts of the bed without twisting your body. A sternum pad supports your torso so you can lean forward and ease strain on your lower back. Move the cart forward by pushing the rear wheels with your hands, wheelchair fashion, or scoot along with your feet on the ground. Prop your harvest container on the front corner of the cart frame, within easy reach. The front wheel swivels for easy steering.



Benefits of Using a Harvest Cart

Less fatigue and discomfort. Prolonged kneeling to harvest, transplant, or weed puts small-scale growers in one of the highest risk groups for occupational injuries. Harvesting from a seated position eliminates knee strain and is less tiring for the back, hamstrings, and torso. Kneeling requires at least 25% more energy and stooping requires at least 45% more energy than sitting does.

Harvest Speed and Posture Analysis	Without Cart	With Cart
Avg. harvest speed (mins/3lb crate)	7.8	4.6
% time spent in unacceptable postures	46	0
% time spent in marginal postures	48	93
% time spent in acceptable postures	6	7

This data is based on a case study with the same worker performing the same task. Postural analysis was compiled using the Ovaco Work Analysis System.

Faster. Using the cart lets you harvest the same amount of greens 40% more quickly. Faster har-

Harvest Cart

vesting and quicker time to the cooler maintains high crop quality.

Less soil compaction. Instead of kneeling or walking in the crop row or bed, the cart supports your weight. Your weight, plus the weight of the cart, is transferred through the wheels to the paths between the crops.

Improves profits. Cutting harvest time can save labor costs. A typical scenario might be that your labor costs are \$7.00 per hour, and you harvest four days a week. If you save 30 minutes per harvest day by using the cart, in 11-18 weeks the cart will have paid for itself. If the harvest cart prevents back or knee pain, you might also save money on medical bills.

Where Can I Get a Specialized Harvest Cart?

These carts, designed by Bob Meyer and Hal Bohne of the University of Wisconsin Agricultural Engineering Lab, are not available in stores or catalogs. We can provide plans for you to make your own cart from readily available materials. Some welding is required, which can easily be done by your local welder. Locate a welding shop in the phone book under welding-custom fabrication. Buy the parts at

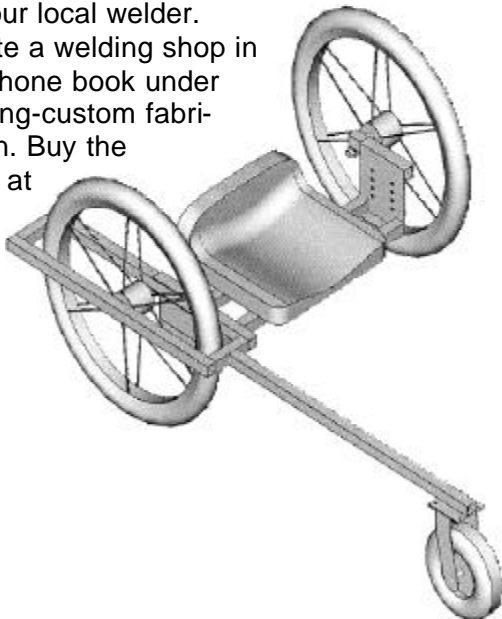

a hardware store or from a tool and equipment catalog such as: Northern Hydraulic, P.O. Box 1499, Burnsville, MN 55337. 800-533-5545. (This reference is provided as a convenience for our readers. It is not an endorsement by the University of Wisconsin.)

How Much Will it Cost?

The parts for this cart cost about \$150. Labor costs, custom welding, or welding shop rental times will vary.

Steel: (1 1/4" square tubing, 1/8" wall thickness. 3/32" flat stock for gussets and supports)	\$ 15
Seat: (small tractor replacement)	\$ 28
Rear Wheels: (26" pneumatic)	\$ 28/ea.
Front Wheel: (10" swivel caster)	\$ 36
Swivel: (boat seat)	\$ 15
Total	\$150

Cart width should be 6"-12" wider than beds so that wheels will roll in the paths. Overall cart length is 42 1/2".

Contact Information

This material was developed by the Healthy Farmers, Healthy Profits Project, whose goal is to find and share work efficiency tips that maintain farmers' health and safety and also increase profits. For more information, visit our web site at <http://bse.wisc.edu/hfhp/> or call 608-265-9451.

Healthy Farmers, Healthy Profits Project,
Department of Biological Systems Engineering,
College of Agricultural and Life Sciences,
University of Wisconsin, 460 Henry Hall,
Madison, WI 53706.

Feel free to reproduce; please mention source.



Participatory Ergonomics Team

Problem:

Management and workers want to decrease injuries, but lack knowledge of ergonomics. Instructions on safe practices from outside experts in ergonomics or from management may fall on deaf ears.



- Management may be unaware of the severity and costs of ergonomic hazards.
- Changes made without worker input may be resisted. Old habits die hard.
- Ergonomics consultants can address immediate problems, but not ongoing education and follow-through.

One Solution:

Set up a joint ergonomics team of workers and managers.



- Knowledge of ergonomic principles leads to better solutions.
- Workers' job insight ensures the most important problems will be addressed.
- Workers' day-to-day knowledge provides a reality check on suggestions.
- Ergonomic concerns filter down from management team members to other levels of management, and from worker team members to rest of work force.
- Ergonomics experts and other resources can be brought in as consultants, as needed.
- Team can develop ongoing ergonomics education program and address new problems as they arise.

Ergonomics Team

Why Set Up a Participatory Ergonomics Team?

The participatory approach—involving workers and managers—produces the best ideas for preventing injuries. It also means that the ideas will be used, rather than collecting dust on the shelf. The participatory approach recognizes workers' knowledge and uses it both to single out the worst hazards and to develop solutions. Workers are in on the decisions about which jobs to improve, and how to improve them. They spread the knowledge of ergonomics and of the specific solutions to the rest of the work force.

Who Should Be On an Ergonomics Team?

Keep the size of the team small. Involve production workers and supervisors from the different departments—the people who will put the job improvements into use—and also the maintenance workers or engineers who will build the needed tools. Include a representative from each major type of job. It is important that the person who has decision-making power to implement the team's recommendations also be a team member.

Hold training and meetings during work hours; participation should be seen as part of the job, not an extracurricular activity. Hold training and meetings in the workers' first language. Sometimes this will mean using two languages, with translation.

What Are the Tasks of an Ergonomics Team?

1. The team should receive training in basic ergonomic principles. See the Resources section of this pamphlet for a good training video, *Listen to Your Body*, and a pamphlet, *Blueprintstwo*.
2. Identify the ergonomic risk factors in each major job.
3. Rank jobs by urgency, based on the risk factors present, number of people affected, and number of injuries. The team should have permission to look at all injury and cost data, to help them set priorities.
4. Develop solutions. Look at equipment or tools available in your industry or in other industries, or design new tools. Call in engineers or consultants as necessary. Look for ways to change how the job is designed, so work safety is built into the job. This is

more effective than changes in instructions or work rules.

5. Try out the solutions in daily use.
6. Get feedback and modify as necessary.
7. As it works, the team should keep management and the work force fully informed of its goals, progress, and successes.
8. Design a program to educate all workers on ergonomic principles. For example, at one tree nursery, the Ergonomics Team drew up information sheets, specific to the nursery, that outlined the risk factors for the major jobs and some methods to work more safely. This information became part of new employees' orientation training.

What Are the Costs of an Ergonomics Team?

Workers' and managers' time spent working on the team should be paid at their regular rate. New tools may have to be ordered or built. Reduced costs because of decreased injuries should outweigh these short-term costs.

Where Can I Get More Information About Setting Up an Ergonomics Team?

See the Resources section for a video, *Ergonomic Programs That Work*, and a pamphlet, *Elements of Ergonomics Programs*.

Where Can I Find a Consultant on Ergonomics?

Look in the Resources section for a list of free OSHA consultation services (there is one in each state).

Contact Information

This Tip Sheet was produced from material developed by the Safety and Health Assessment and Research for Prevention (SHARP) Program, Washington State Department of Labor and Industries.

SHARP, Washington State Department of Labor and Industries, PO Box 44330, Olympia, WA 98504-4330. Or visit <http://www.wa.gov/lni/sharp/>.

New Rakes for Harvesting Berries

Problem:

Harvesting blueberries with a traditional rake is hard on the body.

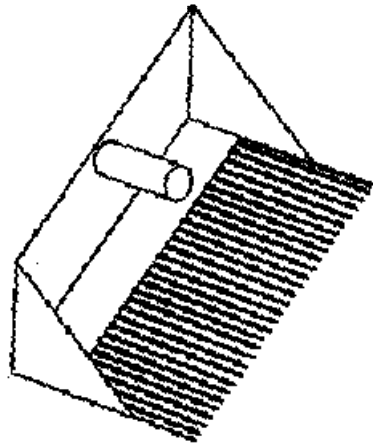

- Stooped position hurts the back.
- Thin handle is hard to grip comfortably.
- Rake design causes worker to flex wrists and to use pinch grip with fingers, risking tendinitis in wrists and hands.
- Steel rake is heavy, up to four pounds.

Two Solutions:

1. Modify existing rake.

- Add electrical tape or pipe foam to make the handle diameter right for the worker.

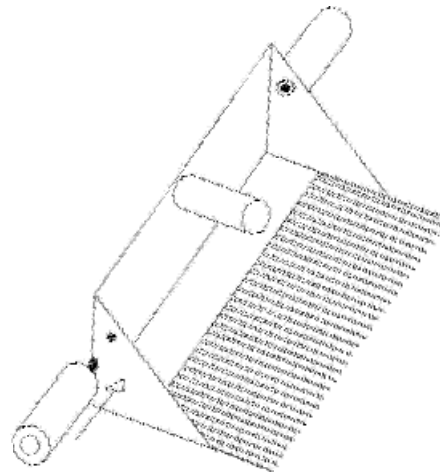

- Add a handle on each side of the rake, so it can be held with both hands.

- Use an aluminum rake rather than steel.

2. Use a stand-up rolling rake.

- Can be used while standing upright.
- Eliminates awkward pinch grip with hand.

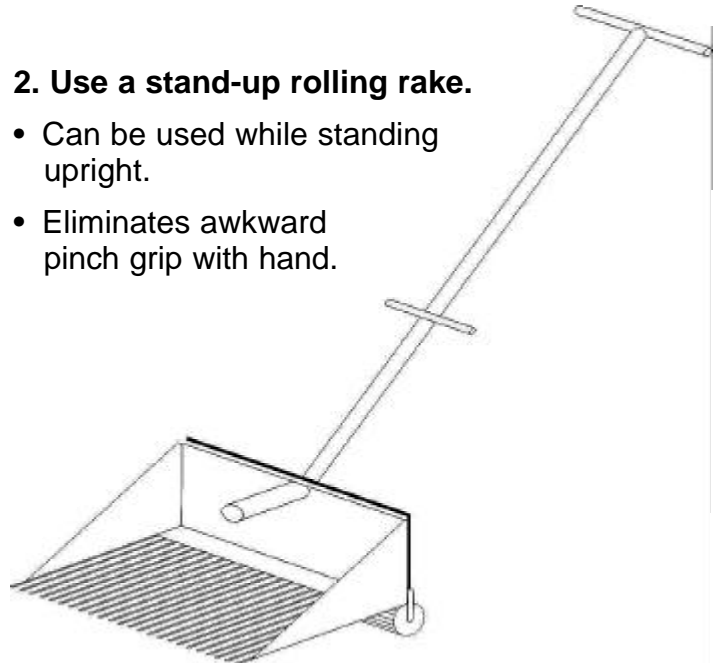

Blueberry Rake

Why Not Use a Traditional Rake?

Because wild blueberries grow only about eight inches from the ground, harvest workers rake in a very stooped position. Their short-handled steel or aluminum rake, costing about \$60, causes the wrist to flex as the rake is dragged through the berries. To help guide the rake, most workers hold on to its side, using a pinch grip, which can cause tendinitis in the hands. The rake handle is too thin, at 1¼ inches in diameter, for most people to use comfortably.

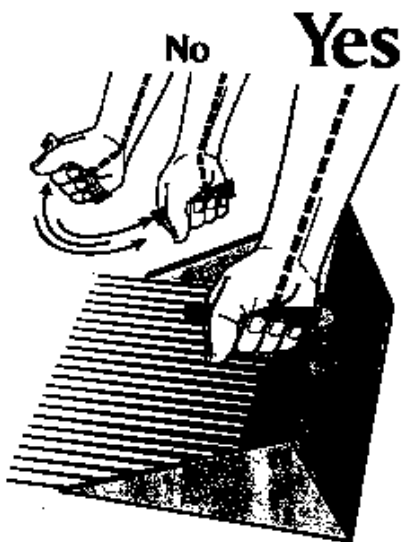

Encourage workers to keep their wrists straight while working.

How Can I Improve a Traditional Rake?

1. Add electrical tape or foam pipe insulation, available in hardware stores, to enlarge the diameter of the center handle. The best size is 1-3/8" for small hands, up to 2-1/8" for large hands, with an average of 1-3/4". When gripping, the finger and thumb should overlap slightly.

2. Attach a handle on each side of the rake, which workers can grab without using a pinch grip. The idea is to have one hand on the center handle and the other hand on one of the side handles. Holding the rake by two hands will stabilize it and decrease its tendency to swivel when raked through the plants. Also, having a handle on either side will allow the worker to switch the main raking hand.

Use handles that have a rubber or plastic coating and that are 1-3/8" to 2-1/8" in diameter, depending on the hand size of the worker who will be using the rake. Drill a hole in each side of the rake. Put the bolt of the handle through the hole and connect with a washer and nut on the inside of the rake (see drawing on page 19).

3. Encourage workers to keep wrists straight while raking (see illustration, left). They should let the larger muscles of the shoulder and elbow do the work, and switch hands often.

4. Encourage workers not to fill their rakes or buckets too full. Tell them to stop if they feel pain, and to put something cold on the sore spot. Encourage stretch breaks.

Where Can I Get a Long-Handled Rake?

Acadian Machine Works Ltd.
Tignish, Prince Edward Island C0B 2B0 Canada
902-882-2349
Cost: \$550 Canadian or about \$300 U.S., plus shipping

This rake rolls on two wheels, making it easy to push through the bushes.

Some workers have also made homemade stand-up rakes, by attaching a long handle to a traditional rake, via a frame around the back and a cylindrical roller (like a rolling pin) attached to the bottom. Such homemade roller rakes are heavy, but still easier on the back than the traditional rake.

Cost Analysis

At a cost of \$300, it would take 17 to 30 hours for a blueberry harvester to pay for a manufactured stand-up rake. The rake should be sturdy enough to last for many seasons.

Contact Information

This Tip Sheet was produced by NIOSH.

NIOSH, 4676 Columbia Parkway, Cincinnati, OH 45226. Or visit <http://www.cdc.gov/niosh>.

Power Cutter for Woody Plants

Problem:

Thick woody plants are difficult to cut with small propagation shears. Repetitive gripping can contribute to chronic problems in the hand, wrist, and arm.



- Nursery workers use hand shears to make cuttings from plants for future propagation. Some plants, such as juniper, have thick and woody stems.
- Highly repetitive hand work can contribute to chronic injury of the hand, wrist, and arm (such as tendinitis or carpal tunnel syndrome). When workers have to squeeze forcefully, the risk of injury is increased even more.
- Repetition leads to fatigue of small muscles and to increased wear on tools.
- Besides the injury factor, woody plants can be prickly and difficult to handle.

One Solution:

Use a bench-mounted power cutter to relieve repetitive gripping and speed the work.



- Reduces need for repetitive and forceful gripping.
- Reduces need for handling of cuttings.
- Can improve productivity.

Power Cutter

How Does the Cutter Work?

The cutter uses air pressure to power a pneumatic cylinder that closes and opens a set of mounted hand shears, which have been modified for this purpose. Each cycle is activated by a light touch of the plant material against the trigger lever of an air micro-switch.

How Does the Cutter Affect Cutting Quality?

The cutting quality is unchanged, because the blades are identical to those of current hand shears. Workers new to the powered cutter will need one to two hours of practice before they can use it as well as the hand shears.

How Does the Cutter Affect Productivity?

Reducing fatigue may increase productivity over the course of the day. Also, workers with physical limitations may be able to use the machine much more easily than the hand shears, and thus be more productive.

Where Can I Get a Power Cutter?

Contact:
MG Enterprises
Rocky Canyon Road
Creston, CA 93432

Prices will likely run about \$1,000 for a smaller cutter and \$1,250 for a larger one.

Contact Information:

This Tip Sheet was produced by the University of California Agricultural Ergonomics Research Center under a grant from the National Institute for Occupational Safety and Health.

UC Ag Ergonomics Research Center, Bio & Ag Engineering, UC Davis, One Shields Avenue, Davis, CA 95616-5294.
Or visit <http://ag-ergo.ucdavis.edu>.

Metered Liquid Applicator

Problem:

Manual application of liquids (such as growth regulators) with a spray-wand can cause worker injury, as well as waste of chemicals and plant loss.



- Worker must squeeze and hold spray-wand trigger up to 25 times per minute.
- Highly repetitive hand closure can cause inflammation of the tendons in the carpal tunnel.
- Mental counts to “time” the discharge can result in inconsistent or improper amounts.
- Many spray-wands currently in use are not appropriate for long reaches, resulting in prolonged poor wrist posture.

One Solution:

Use a semi-automated, metered liquid applicator to provide a precise dose to each plant and to eliminate repetitive hand closure.

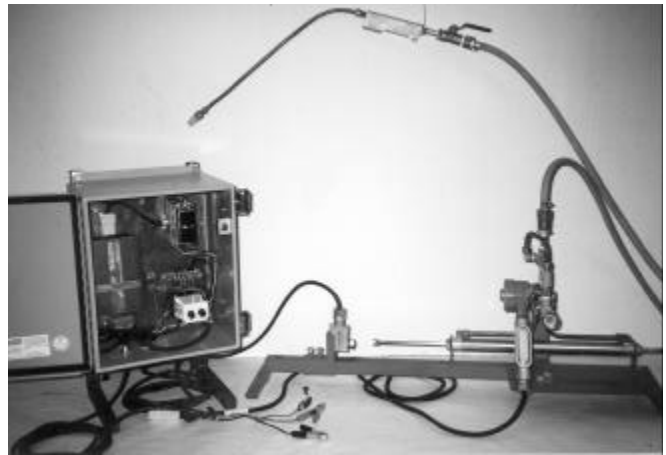

- Eliminates virtually all of the repetitive hand-squeezing motion.
- Can reduce waste of chemicals and plant loss.
- Curved wand design improves wrist posture for long reaches.
- Can improve productivity.
- Can document production, if fitted with a counter.

Metered Liquid Applicator

How Does the Applicator Work?

The system has three parts: a) the electric controls box, b) the metering cylinder assembly, and c) the check valve-fitted spray-wand. It uses a tractor's 12-volt battery to power the timer module and to create 120-volt electricity that powers the solenoid valve. Liquid is alternately supplied to each side of the double-acting cylinder, which meters a precise dose through the discharge hose. An adjustable momentary delay provides time between discharges to move the wand to the next plant. A spring-loaded check valve at the end of the spray wand ensures that excess liquid does not flow out of the spray gun between discharges.

How Can I Make a Metered Liquid Applicator?

The applicator is composed of off-the-shelf components with the exception of a steel frame. It requires a qualified electrician for wiring and assembly of the electrical components. Material costs should be about \$500.

Caution! Proper assembly of the liquid applicator requires specific expertise. Consult a trained electrician or engineer for advice and assistance. The assembled liquid applicator should be tested initially using potable water, not chemicals.

The electric controls box houses the power converter, ground fault interrupter, system toggle switch, terminal strip, fuses, and timer module.

The cylinder metering assembly consists of a steel frame with a double-acting double-rod cylinder, an adjustable stop for the cylinder, an air purging valve, and a solenoid valve with inlet/outlet hose adapters.

The spray gun can be any pistol-style wand, or one modified to pistol style, to allow for a neutral wrist position with an outstretched arm.

For a free parts list and detailed instructions on how to make the metered applicator, write to:

UC Ag Ergonomics Research Center
Bio & Ag Engineering, UC Davis
One Shields Avenue
Davis, CA 95616-5294
Or visit <http://ag-ergo.ucdavis.edu>.

Operational Tips:

Trapped air in the solenoid valve, tubing, cylinder, or hose will affect the accuracy of the system. To help avoid this problem, the cylinder ports face upward, and the 4-way valve is located directly above the cylinder. A bypass valve for purging air from the hose is provided. Rough handling of the discharge hose can cause unwanted discharge. Handle the hose relatively gently unless the spray-wand valve is closed. For more information about this system, please visit the UC-AERC web site at <http://ag-ergo.ucdavis.edu>.

Contact Information:

This Tip Sheet was produced by the University of California Agricultural Ergonomics Research Center under a grant from the National Institute for Occupational Safety and Health.

UC Ag Ergonomics Research Center, Bio & Ag Engineering, UC Davis, One Shields Avenue, Davis, CA 95616-5294.
Or visit <http://ag-ergo.ucdavis.edu>.

A Rolling Dibble Marker for Easy Transplant Spacing

Hand transplanting seedlings into the field can be tedious and time-consuming. Some growers lay a tape measure or knotted string on the planting bed to space transplants evenly. Others just estimate plant spacing with their eyes. Many growers then use a hand trowel to dig holes for the transplants. A rolling dibble marker, or dibble drum, is a tool that helps you transplant seedlings faster and more accurately. The hand-pulled tool rolls across the planting bed, punching or scooping transplant holes into the soil at regular intervals.



In loose soil, the dibble drum will dig holes, but in heavy or compact soil it will mark locations for transplant holes. After rolling the dibble drum along your planting bed, plant transplants into the holes or scoop marked holes with a trowel.

Why Use a Dibble Drum?

Saves time. You can set out, plant, and water transplants 24% faster when using a dibble drum to space and dig holes, compared to visually estimating spacing and using a trowel.

How Does It Work?

You walk down the path beside the prepared planting bed, pulling the dibble drum behind you by its handle. As it rolls along, “dibbles,” or scoops, which are screwed into a PVC drum at regular intervals, create indentations in the soil for transplants.

More accurate. If you mark your planting bed with a dibble drum, you will ensure exact spacing of your transplants in a grid pattern, even when the task is performed by inexperienced workers. Consistent spacing makes weeding easier, since you can use a hand hoe or wheel hoe in two directions or use a mechanical cultivator. Accurate plant spacing will conserve bed space and maintain plant quality. Even experienced growers tend to overestimate plant spacing, which can waste productive land. If growers underestimate spacing, plants can be crowded

and yield might suffer.

Easier on the body. Using a dibble drum to space transplants lets you stand instead of stooping or kneeling to mark transplant spacing.



Traditional transplanting often uses a measuring stick (above) or knotted string (right) to space plants.



Rolling Dibble Marker

Simple. It can be complicated and time-consuming to explain how to space transplants to inexperienced field hands. With a dibble drum, you can instruct workers to simply roll the drum down the planting bed and set one plant in each hole.

How Do I Make a Dibble Marker?

This rolling dibble marker, designed by Bob Meyer of the University of Wisconsin Ag Engineering Lab, is made from readily available hardware, lumber, and PVC pipe. The drum is a section of 12" diameter PVC pipe (\$45-\$50) commonly used for sewer connections. Check with plumbing supply stores and ask for a section as long as your bed is wide. Parts for the dibble drum will total approximately \$100.

Materials and Assembly

Drum:

- (1) 12" diameter PVC pipe cut to length of bed width.

Scoops:

- (1) 2"x18" PVC pipe cut into (6) 3" sections which are each cut in half lengthwise at a 45° angle.
- (12) 2" metal angle brackets, fastened to each scoop and then to the PVC drum.

Axle assembly (galvanized plumbing fittings):

- (2) 1'x1'x3/4" plywood pieces, cut to fit end of drum and fastened with screws.
- (2) 3/4" floor flange, screwed into center of plywood.
- (2) 3/4"x6" nipple threaded through PVC handle "T" and screwed into flange.
- (2) 3/4" coupler or end cap.

Handle assembly:

- (1) 1"x10' PVC pipe, cut into 4 sections (42", 24", 25", 13").
- (2) 1" PVC "T", to slip over each axle.
- (1) 1" PVC 90° elbow to connect the 13" handle section to the 42" section.
- (2) 1" PVC 45° elbow.

Glue the 42" section and 24" section each into an axle "T". Glue a 90° elbow to the 42" section and a 45° elbow to the 24" section. Glue the 13" section to the 25" section with a 45° elbow. Attach the other end of the 13" section to the 90° elbow, and the other end of the 25" section to the other 45° elbow.

Misc.:

- (48) 1/4"x1" machine screws, (56) 1/4" lock washers, (56) 1/4" nuts, (16) 1/4"x1" wood screws, (8) 1/4"x2" pan head machine screws.

PVC glue.

Exterior wood varnish or paint.

Contact Information

This material was developed by the Healthy Farmers, Healthy Profits Project, whose goal is to find and share work efficiency tips that maintain farmers' health and safety and also increase profits. For more information, visit our web site at <http://bse.wisc.edu/hfhp/> or call 608-265-9451.

Healthy Farmers, Healthy Profits Project, Department of Biological Systems Engineering, College of Agricultural and Life Sciences, University of Wisconsin, 460 Henry Hall, Madison, WI 53706.

Feel free to reproduce; please mention source.

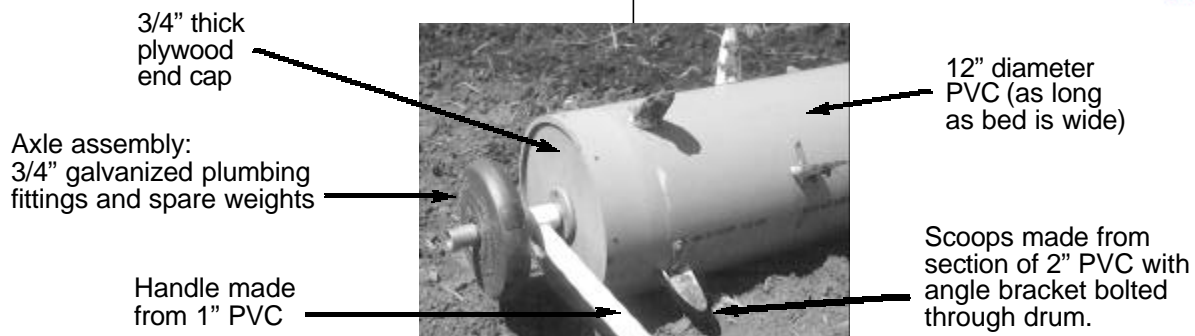

Scraper Handle

Problem:

Long-handled metal floor scraper (used for cleaning up dirt and mud) requires lots of force to grip and to push.



- Nothing to grip.
- Cannot comfortably be pushed with the torso.

What's Wrong With a Plain Shaft Like a Broom Handle?

Dirt and mud packed on the floor of a work area can be thick and heavy. It's hard to hold the handle tightly enough to push as hard as you need to. If workers lean into the scraper to use the whole force of their bodies, it hurts when the end of the shaft jabs into their stomachs.

How Is a Bar Handle Added?

You can use two hollow pipes (four- or five-inch-length nipples), attached to the shaft with a pipe T fitting, or you can weld an eight-inch length of pipe nipple direct-

One Solution:

Attach an eight-inch bar handle to top of scraper.

- Gives a better grip.
- Disperses contact force over a larger area.



ly to the shaft. If the original shaft is made of wood, this will mean replacing it with pipe as well. Use a ¾-inch pipe shaft. Being hollow, the pipes will not make the scraper overly heavy. Then wrap the nipples with foam pipe insulation to cushion the handle.

Contact Information

This Tip Sheet was produced from material developed by the Safety and Health Assessment and Research for Prevention (SHARP) Program, Washington State Department of Labor and Industries.

SHARP, Washington State Department of Labor and Industries, PO Box 44330, Olympia, WA 98504-4330. Or visit <http://www.wa.gov/lni/sharp/>.

Simple Solutions Are Cost-Effective!

The next four tip sheets were written for small fresh-market vegetable farms, where produce is sold without processing, directly to stores, restaurants, or consumers. For these four items, researchers from the University of Wisconsin Biological Systems Engineering Department made estimates of costs, profit improvements, and work hours affected. As you can see, each improvement gives a lot of bang for the buck.

ESTIMATED WORK FORCE AND LABOR HOURS AFFECTED BY FOUR INNOVATIONS ON A TWO-ACRE MARKET VEGETABLE OPERATION

<u>Innovation</u>	<u>Percent of Work Force Affected</u>	<u>Percent of Work Hours Affected</u>	<u>Possibility for Profit Improvement</u>	<u>Start-Up Cost</u>
Net bag wash system	60%	10-20%	High	\$24 (six bags)
Standard containers	75-95%	10-20%	Medium-high	\$120 (12 containers)
Pallets and hand truck	80%	20-50%	High to very high	\$750 (75 pallets & truck)
Packing line layout	75-95%	15-25%	Low to medium	\$150-\$400

SOURCE: All data are best estimates based on field observations and professional judgment of project staff.

Mesh Bags: Easy Batch Processing

Problem:

Washing leafy greens by hand is back-breaking and time-consuming.



- Worker must stoop, lift, and grip repeatedly.
- Slow washing reduces crop quality.
- There is static load on arms while holding produce to drain.
- Hands are in direct, frequent contact with cold water.
- Rough handling lowers crop quality.

One Solution:

Use mesh bags to speed the process.



- Erect posture while removing and draining leaves.
- Greater amount per trip: can use batch processing.
- Able to wash 50% more greens (by weight) in the same amount of time.
- Faster process maintains crop quality.
- Hands spend less time immersed in cold water.
- Less chance of leaf damage from crushing.

Mesh Bags

When Would I Use a Mesh Bag?

A mesh bag is a woven or knotted polyester or nylon sack that lines your harvest containers or wash basins. When you need to wash a large number of small items (such as salad greens, peas, beans), a mesh bag can save you time and help reduce stress and strain on your body.

What Is 'Batch Processing'?

You can move a large amount of produce at one time through the harvest, washing, and drying process. This amount, or batch, allows you to speed the entire process because you cut out many short repetitions along the way. For example, you can line your harvest container with a mesh bag, then lift the entire bag and its contents into the wash basin. Leave the produce in the bag to soak and rinse, and then lift the entire batch to dry. Dry light produce by placing the bag into a commercial salad spinner, or use an old washing machine set to "spin" cycle. The mesh allows water to drain out. If you don't have a spinner or washing machine to dry produce, spin the bag lasso-style in the air.

Will Using Mesh Bags Save Me Money?

Mesh bags cost approximately \$2-\$5 apiece, and the time savings from batch processing with a mesh bag will increase your profit. You can lift 50% more produce by weight with a mesh bag compared to by hand without a bag. Indirect savings will occur from preventing stress and strain on your body. Produce quality is improved with faster washing and drying, and produce loss from repeated handling is also prevented.

Where Can I Get Mesh Bags?

Several companies sell mesh bags for various uses such as laundry bags and storage bags. Check ads in magazines such as the *American Vegetable Grower*, *Growing for Market*, and *The Packer*. The Nylon Net Company sells a 22"x22" square bag with 1/4" mesh. Cady Industries sells 32"x27" knotted McKnit bags. These sources are provided as a convenience for our readers. They are not an endorsement by the University of Wisconsin-Extension, nor is the list exhaustive.

Cady Industries
P.O. Box 2087
Memphis, TN 38101
800-622-3695

Nylon Net Co.
845 North Main St.
Memphis, TN 38107
800-238-7529

Contact Information

This material was developed by the Healthy Farmers, Healthy Profits Project, whose goal is to find and share work efficiency tips that maintain farmers' health and safety and also increase profits. For more information, visit our web site at <http://bse.wisc.edu/hfhp/> or call 608-265-9451.

Healthy Farmers, Healthy Profits Project,
Department of Biological Systems Engineering,
College of Agricultural and Life Sciences,
University of Wisconsin, 460 Henry Hall,
Madison, WI 53706.

Feel free to reproduce; please mention source.



Standard Containers

Problem:

Non-uniform containers are difficult to use.



- Carrying round crates or baskets is awkward; center of gravity is too far from the body.
- Non-stacking containers require you to stoop and bend more often.
- Missing and poor handles make crates difficult to carry.
- It is hard to estimate crop yield using non-standard containers.
- Containers may be too large or too small for the product.
- Cardboard and wooden crates are hard to sanitize.

One Solution:

Standardized containers for your produce.



- When you carry square or rectangular containers, the center of gravity is close to your body.
- Containers stack, which saves on bending and stooping.
- Containers have molded, sturdy handles.
- Crop yield is easy to estimate with standard-sized containers.
- Several sizes are available for different uses and loads.
- Plastic containers are easy to sanitize.

Standard Containers

Are Standard Containers Worth It?

Standard containers cost about \$5-\$10 apiece.

Their durability, versatility, and ease of use may save you money in the long run. More efficient work using standard containers—compared to using assorted baskets, boxes, crates, and pails—may produce indirect savings. These would include faster harvest and handling, less stress and strain on your body, and easier monitoring of crop yield. You can save field time by tossing empty containers to strategic places along the harvest row.

Standard containers can be used to wash and drain produce as well as for transport. Some have rounded bottoms so they can be used as “sleds” in the field or used as wash basins in the packing shed.

Standard containers made of plastic polymers will last for many years. Standard containers nest to save storage space. You can help prevent the spread of plant diseases by regularly washing plastic containers. Be sure to sanitize all surfaces of the containers, both inside and out. Containers should not be stacked on soil to dry, nor should you stack cleaned containers if they have been in contact with soil. Containers that fit the size and weight of your produce may improve harvested crop quality, since less loss will occur from damage.

Are There Tools that Complement Standard Containers?

Standard containers can be stacked on narrow pallets or full-sized pallets and then entire pallet loads can be moved with a hand truck or hydraulic pallet jack.

Where Can I Get Standard Containers?

A number of companies sell standard containers. Check ads in magazines such as the *American Vegetable Grower*, *Growing for Market*, and *The Packer* for sources. The following list of companies is provided as a convenience for our readers. It is not an endorsement by the University of Wisconsin-Extension, nor is it exhaustive.

Buckhorn Inc.
55 W. TechCenter Dr.
Milford, OH 45150
800-543-4454

CSA Works
121 Bay Rd.
Hadley, MA 01035
413-586-5133
recycled containers; bulk orders for
small- and medium-sized growers

Perstorp Xytec, Inc.
9350 47th Avenue SW
Tacoma, WA 98499
800-423-3221

Contact Information

This material was developed by the Healthy Farmers, Healthy Profits Project, whose goal is to find and share work efficiency tips that maintain farmers' health and safety and also increase profits. For more information, visit our web site at <http://bse.wisc.edu/hfhp/> or call 608-265-9451.

Healthy Farmers, Healthy Profits Project,
Department of Biological Systems Engineering,
College of Agricultural and Life Sciences,
University of Wisconsin, 460 Henry Hall,
Madison, WI 53706.

Feel free to reproduce; please
mention source.



Narrow Pallet System

Problem:

Carrying heavy boxes by hand is strenuous and awkward.



- Carrying loads up to 75+ pounds is tiring.
- Can only move four boxes at once.
- Awkward carrying positions.
- Must stoop, bend, and lift often.
- Poor handles on boxes.

One Solution:

Roll a stack of boxes with a hand pallet truck.



- Carry loads of 500+ pounds with less effort.
- Can move up to 16 boxes at once.
- Allows loads to be rolled.
- Less stooping, bending, and lifting.
- Better carrying grip, lower weight at handles.

Narrow Pallet System

What Is a Pallet Truck?

Pallet trucks are similar to regular hand trucks (dollies) with the exception of having pivoting forks instead of a plate metal shoe. If you stack your load on a small pallet (14"x24"), you can position the forks underneath and roll away as many as 16 5/9 bushel boxes. A pallet truck can be tilted (by releasing the forks) for loading and unloading and locked into an upright position to tip back and roll the load.

Why Not Use a Regular Hand Truck?

With a hand truck, you need to push a stack of boxes forward in order to squeeze the shoe under the stack. This can make the stack unstable. A pallet system keeps the load upright and stable until the truck is locked into position for moving. The shoe of a regular hand truck is fixed, which limits its use in tight quarters. Standard stackable containers tend to slide around on a regular hand truck when full because the bottom of the container has a smaller footprint than the top. But using a pallet underneath the standard containers, you eliminate the sliding.

Why Not Use a Regular Pallet?

Many small-scale growers store and pack produce in converted barns, older buildings, and coolers with tight spaces and narrow doorways. A full-size pallet and pallet jack require a very flat, smooth, hard surface to roll easily. Pallet trucks, with their narrow size and pneumatic wheels, roll easily through doorways and on rough surfaces.

How Much Time and Energy Will It Save?

There are several ways a pallet truck can increase your efficiency compared to moving boxes by hand.

1. The number of times you lift or lower a box can be cut in half.
2. If you would normally carry 3 or 4 boxes at a time, you can cut your total number of trips by 75%-82%.
3. By using a pallet truck you can cut the time you spend carrying boxes by 60%.

Cost Analysis

A new custom-made pallet truck with pallets costs \$750. At \$7.00/hr., you'd need to save yourself 143 hours for the system to pay for itself. Ten hours saved per month (30 minutes per weekday) means the system pays for itself in a little over 14 months of use. If you commonly visit a chiropractor or massage therapist to relieve back pain, the pallet truck system can pay for itself in less than 12 visits (at \$50/visit).

Where Can I Find a Pallet Truck?

Pallet trucks are commonly used for feed and seed sacks. Look in feed mills and co-ops for used pallet trucks which you can retrofit with a larger back frame to support two stacks of boxes. Valley Craft makes pallet trucks with the wider frame; these trucks are distributed by several dealers. Look under "materials handling" in your phone book or contact the following companies. This list is provided as a convenience for our readers. It is not an endorsement by the University of Wisconsin-Extension, nor is it exhaustive.

Fastenal Co.
1117 Ashwaubenon St.
Green Bay, WI 54304
414-432-9181

Stoffel Equipment
P.O. Box 23341
Milwaukee, WI 53223
414-354-7500

Reynolds Sales and
Equipment
4255 Sunset Ridge
Cottage Grove, WI 53527
608-839-3417

Valley Craft
2001 South Highway 61
Lake City, MN 55041
800-328-1480
carts@valleycraft.com

Contact Information

This material was developed by the Healthy Farmers, Healthy Profits Project, whose goal is to find and share work efficiency tips that maintain farmers' health and safety and also increase profits. For more information, visit our web site at <http://bse.wisc.edu/hfhp/> or call 608-265-9451.

Healthy Farmers, Healthy Profits Project, Department of Biological Systems Engineering, College of Agricultural and Life Sciences, University of Wisconsin, 460 Henry Hall, Madison, WI 53706.

Feel free to reproduce; please mention source.



Packing Shed Layout

Problem:

Packing produce in an unsystematic manner wastes time and effort.



- No clear path for product and workers to follow.
- Wash tubs do not drain; they must be carried and tipped to empty them away from work area.
- Table height inappropriate for task or individual worker.
- Used window screens are difficult to sanitize.
- No shade for workers or produce.
- Clutter impedes efficient work.

One Solution:

Design a well-organized, clear, step-by-step task and product flow.



- Straight line flow for product and worker.
- Drain empties washtub and drainpipe leads dirty wash water away from work area.
- Table heights adjusted to fit task and individual.
- Screen tables made from galvanized hardware cloth are easy to sanitize.
- Shade has been provided for the workers and produce.
- Supplies are kept where they are needed.

Packing Shed Layout

Why Analyze My Packing Shed Layout?

You may be able to save time and effort by slightly changing your current routine or habits.

How Can I Analyze My Packing Area?

On paper, diagram the flow of your product from field to packing box to cooler or truck, and note work stations. Have an outsider describe the flow so you don't overlook any details you might take for granted. You can also videotape the packing process.

Will Rearranging My Packing Area Save Me Money?

Any time saved during produce packing will save money. Indirect savings will occur from creating a more comfortable work area that will be healthier and less hazardous for you. If your produce moves more quickly through the packing process it will maintain higher quality and be fresher when packed.

What Are Some Considerations for Efficient Packing Area Layout?

- Consider the general "flow" of the produce you will be handling. Try to create a step-by-step product line that doesn't waste effort. For example, do all of your crops need to be washed? Do some need to be spray-washed and others dunked? Do you need both water and electricity at some work stations but not others? Could you run two product lines that intersect at a shared work station that has water and electricity? Could you make the product lines intersect at a shared work station where boxes are packed, for example? Or circular product lines that intersect at the shared work station? Could you use some sections of roller table?
- Is your space large enough for your packing needs?
- Is there plenty of light?

- Is the floor level and smooth to allow you to use wheeled carts or handtrucks? Concrete is most effective, followed by asphalt and packed road-base or gravel. Dirt or woodchips hold water and are unsanitary.
- Do you have enough water to frequently change wash water? Do wash tubs drain away from the work area? Could you use a splash guard or collecting trough under a screen table? Do you have a handwashing station?
- Is there enough shade for both produce and workers? Would it help to suspend a tarp, mosquito net, or fan?
- Are supplies such as bags or rubber bands kept where they are needed? Are other items kept out of the way (perhaps overhead)? Is the scale handy and easy to use?
- Are your work station heights adjusted to the individual workers? Efficient work height is half-way between wrist and elbow, measured when the arm is held down at the worker's side. Could some workers use a stepstool? Consider setting up work stations so that you move produce toward your leading hand, for example from left to right for right-handed people. You will have more control and be more accurate.
- Do electrical cords and outlets have Ground Fault Circuit Interrupters? They are cheap and easy to install.

Contact Information

This material was developed by the Healthy Farmers, Healthy Profits Project, whose goal is to find and share work efficiency tips that maintain farmers' health and safety and also increase profits. For more information, visit our web site at <http://bse.wisc.edu/hfhp/> or call 608-265-9451.

Healthy Farmers, Healthy Profits Project, Department of Biological Systems Engineering, College of Agricultural and Life Sciences, University of Wisconsin, 460 Henry Hall, Madison WI 53706.

Feel free to reproduce; please mention source.



Written Materials for Farm Workers

Guidelines

- Use workers' primary language. If that language is Spanish, be sure to use the version your workers use (Central American, Mexican, Puerto Rican). If workers are from different backgrounds, avoid colloquialisms to make the leaflet understandable to all. It's worth the trouble to have the materials translated by someone who is a native speaker of the language.
- Shoot for a fifth-grade reading level.
- Use plenty of illustrations. A picture is worth a thousand words.
- Show and tell not just the wrong way of doing work, but also the right way.
- Get the thinking and input of farm workers themselves. This will produce a result that workers will actually use.

The following leaflets in English and Spanish illustrate these guidelines.

TIPS FOR A HEALTHY BACK

To keep your back healthy, try to:

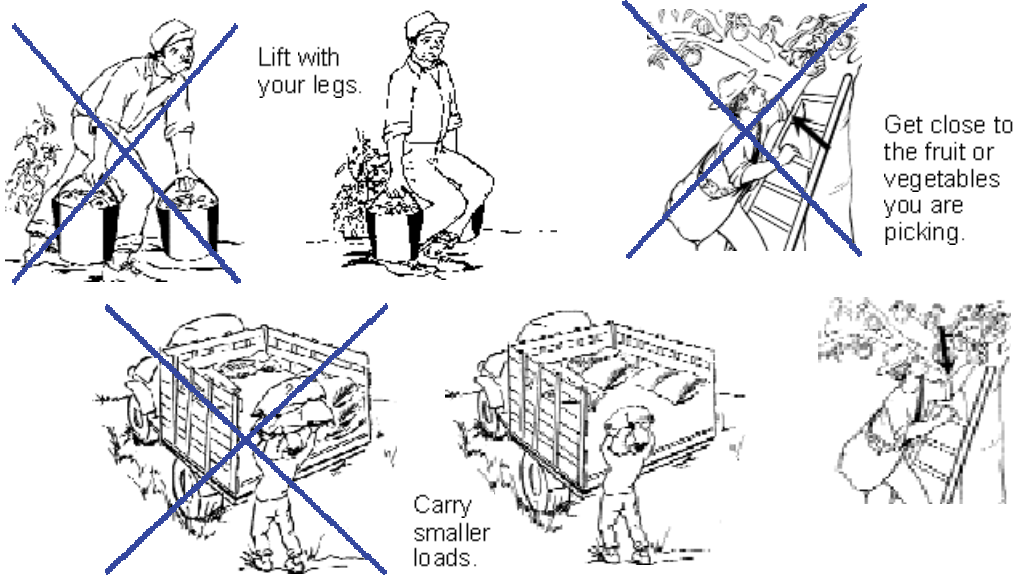

This is what you may feel if you have hurt your back:

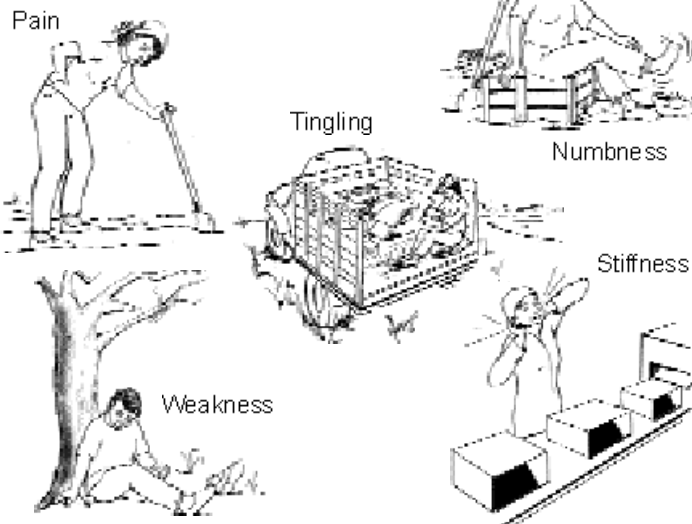

To help yourself or relieve back pain:

Take aspirin, ibuprofen, or acetaminophen.

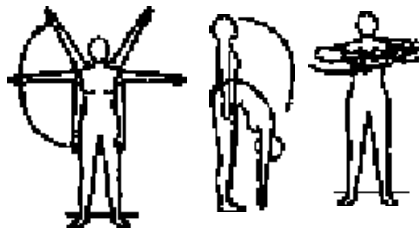

Do stretch exercises.

Back pain affects many of us and makes it difficult for us to work. Sometimes back pain may be caused by the work that we do. But there are symptoms that let us know when our backs have been hurt and treatments to help us feel better.

If you need help to find a doctor or more information, please call:



CALL FOR HEALTH

Information on Health Services for Farmworkers

8:00 a.m. - 4:30 p.m.
Central Time

1-800-377-9968

ACKNOWLEDGMENTS

Produced by:

National Center for Farmworker Health, Inc.
P.O. Box 150009, Austin, Texas 78715
(512) 312-2700, (800) 531-5120

Prepared by:

Viola Gomez, Ed Hendrickson, Dr. Karen B. Mulloy, Dr. Jim Meyers, Tammy Brannen-Smith, Pam Tau Lee, Dr. Mary Lynn Thames, and Madge Vásquez

Translation: Carolina Derber Artwork: Inés Battló

Funding for this project was made possible by the Southwest Center for Agricultural Health, Injury Prevention and Education & the National Institute for Occupational Safety and Health (NIOSH).

CONSEJOS PARA UN ESPALDA SALUDABLE

Para mantener un espalda saludable, trate de:



Levantar con la fuerza de sus piernas.



Acércese a la fruta o vegetales que está recogiendo.

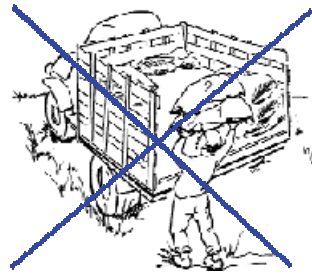

Levantar cargas más pequeñas.



Algunos síntomas de dolor de espalda son:

Dolor



Cosquilleo

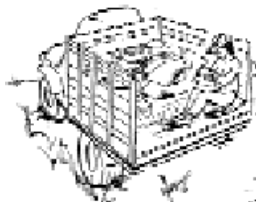

Insensibilidad



Tesura

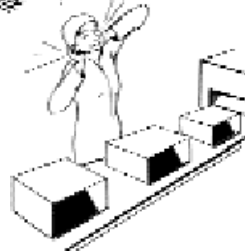

Debilidad



Para ayudarse o para aliviar el dolor de espalda:

Tome aspirina, ibuprofén, o acetaminophen.



Haga ejercicios para estirarse.

El dolor de espalda nos afecta a muchos de nosotros y hace difícil nuestro trabajo. Algunas veces el dolor de espalda es causado por el trabajo que hacemos. Hay síntomas que nos indican que nuestra espalda se ha lastimado y hay tratamientos que nos ayudan a sentirnos mejor.

Si necesita ayuda para encontrar un doctor o más información, por favor, llame al:



CALL FOR HEALTH

Información de Servicios de Salud para los Trabajadores del Campo

8:00 a.m. - 4:30 p.m.
Hora del Centro

1-800-377-9968

AGRADECIMIENTOS

Producido por:

National Center for Farmworker Health, Inc.
P.O. Box 150009, Austin, Texas 78715
(512) 312-2700, (800) 531-5120

Preparado por:

Viola Gomez, Ed Hendrickson, Dr. Karen B. Mulloy, Dr. Jim Meyers, Tammy Brannen-Smith, Pam Tau Lee, Dr. Mary Lynn Thames, y Madge Vásquez

Traducción: Carolina Derber Arte: Inés Batlló

Los fondos para este proyecto, se dieron gracias a la colaboración del Southwest Center for Agricultural Health, Injury Prevention and Education & the National Institute for Occupational Safety and Health (NIOSH).

Company Safety Director Testifies: ‘Ergonomics Works!’

Alethea Leandro is a workers’ compensation specialist with Norton-Parker Insurance Agency, and former Safety Director at Salyer American Fresh Foods in Salinas, California. At Salyer, she implemented ergonomic changes that significantly reduced workers’ compensation premiums for the company. Salyer American employs its own harvesting crews to harvest lettuce and celery on twenty-five small farms.



Q. What background did you have in ergonomics?

I began my career at a small farming operation as the personnel manager. When we moved to a new location we had the opportunity to design our packing shed from scratch. We designed it with the height of our employees in mind, making it more comfortable to stand and work at each location for a long time. This was the start of my ergonomics “training.” Little did I know there was a word for designing the workplace with the human body in mind.

Over the years, I’ve found that most of the equipment we use in California agriculture is designed by and for men. There are many women involved in this industry, and I found, for example, that if things were weighted properly, if the center of gravity was correct, I could use the equipment. If it had been mended or repaired with no concern for balance, I found it difficult to use the equipment safely. We soon began to consider the person using the equipment before any changes or repairs were completed.

Later, my “formal” ergonomics training took place at Human Resources conferences I attended.

Q. What sorts of changes did you implement in the fields?

We made small design changes to the equipment we used to harvest the lettuce. As you know, today produce is packed right out in the field, on equipment that moves through the furrows. On this equipment the workers stand on metal platforms. It’s as tough on the body as standing on concrete all day long, so we put anti-fatigue mats (rubber with holes in it, the same type a bartender uses to stand on behind the bar) on the metal platform, and



A footrest on lettuce-packing equipment.

Work-related injuries dropped by over fifty per cent. Ergonomics works.

also attached a raised bar to rest their feet on, so they could alternate feet and have their lower backs straight. We saw fewer slips and falls getting on and off the equipment and fewer lower back strains due to fatigue.

Another simple change was to pad a lot of solid surfaces. Some of it was not to bruise the food, and some of it was for people purposes. We used foam rubber with plastic over it so it could be washed down. For example, the cutters have to throw the lettuce



Table padded with foam rubber and plastic.

or celery up onto a table to the employee who will pack it. That table is shoulder height with an angle iron edge on it, and people were bruising themselves by standing up and hitting the edge. So we padded that, and by padding it, we also raised the surface of the table for the woman or man who was packing, so they weren't reaching as low for the produce and it didn't require any twisting of the upper body. Along with these ergonomic changes, we painted hazards red to catch the eye—an area where a bolt might be sticking out, for example—

so they could be avoided, and we trained the employees in the benefits of these changes. These are all small, inexpensive changes, but it's amazing the difference they make.

Q. Did you have a hard time convincing your managers to make changes?

I had two factors in my favor. The workers' compensation premiums were high, and California had just implemented legislation that required each employer to have a written Injury and Illness Prevention Program.

I began with small, easily implemented recommendations. Most recommendations were readily accepted and the results were positive. Along with mechanical changes, we began to change management and employee behaviors through training. What I found difficult was that the question most frequently asked was, "What is this going to cost?" rather than "What is this going to save?"

Q. How much savings did you see?

The loss ratio on our workers' compensation went down steadily each year, which in turn brought the premium down. At year four our workers' compensation premium decreased by one million dollars from the high at year two.

Not all of the savings were due to ergonomic or behavioral changes we had implemented. The manner in which workers' compensation was calculated also changed in January of 1995. California began an open rating system, allowing carriers to discount your rate based on your safety programming. Our programming allowed us to benefit in this new system, with significant discounts on our premiums.

Ultimately, the number of work-related injuries dropped by over 50 percent, and we maintained an ongoing decrease in the number of injuries in our fields. Ergonomics works.

The question most frequently asked was, 'What is this going to cost?' rather than 'What is this going to save?'

Resources

National Institute for Occupational Safety and Health (NIOSH). 4676 Columbia Parkway, Cincinnati, OH 45226-1998, 800-35-NIOSH (800-356-4674). Web site address: www.cdc.gov/niosh.

NIOSH Agricultural Health and Safety Centers

Deep-South Center for Agricultural Disease & Injury, Research Education & Prevention. University of South Florida College of Public Health, 13201 Bruce B. Downs Blvd, Tampa, FL 33612-3805. Phone: 813-974-6661.

Southeast Center for Agricultural Health and Injury Prevention. Department of Preventive Medicine, University of Kentucky, 1141 Red Mile Rd., Suite 102, Lexington, KY 40504-9842. Phone: 606-323-6836.

Northeast Center for Agricultural Medicine and Health. One Atwell Road, Cooperstown, NY 13326. Phone: 607-547-6023.

Midwest Center for Agricultural Research, Education, and Disease and Injury Prevention. National Farm Medicine Center, 1000 North Oak Avenue, Marshfield, WI 54449-5790. Phone: 715-387-9298.

Great Plains Center for Agricultural Health. 100 Oakdale Campus, #124 AMRF, The University of Iowa, Iowa City, IA 52242-5000. Phone: 319-335-4412.

Southwest Center for Agricultural Health, Injury and Education. The University of Texas Health Center at Tyler, 11937 US Hwy 271, Tyler, TX 75708. Phone: 903-877-5896.

High Plains Intermountain Center for Agricultural Health and Safety. 154B Environmental Health Bldg., Colorado State University, Fort Collins, CO 80523-1681. Phone: 970-491-6151.

University of California Agricultural Health and Safety Center at Davis. Old Davis Rd., University of California at Davis, Davis, CA 95616-8757. Phone: 530-752-5253.

Pacific Northwest Agricultural Safety and Health Center. Department of Environmental Health, Box 357234, University of Washington, Seattle, WA 98195-7234. Phone: 206-685-8962.

NIOSH Publications

The following are free from the NIOSH Publications Office. Call 800-356-4674 or fax 513-533-8573.

Elements of Ergonomics Programs: A Primer based on Workplace Evaluations of Musculoskeletal Disorders. 1997. A. Cohen, C. Gjessing, L. Fine, B. Bernard, J. McGlothlin, editors. NIOSH Publication No. 97-117. This 132-page book outlines a seven-step process that tells you how to determine whether you need an ergonomics program and how to start one. Chapters include training, reviewing medical data, and developing solutions. Checklists and questionnaires for data gathering are included.

Participatory Ergonomic Interventions in Meatpacking Plants. 1994. By C. Gjessing, T. Schoenborn, and A. Cohen. NIOSH Publication No. 94-124. This 200-page book from NIOSH gives case studies of three companies that set up participatory programs with employees. Although the case studies are in meatpacking plants, the same principles apply in most workplaces.

Other Publications

Easy Ergonomics, A Practical Approach for Improving the Workplace. 1999. Published by the California Department of Industrial Relations, Cal/OSHA Consultation Service. Copies can be obtained at no charge from Cal/OSHA, Manager, Consultation Education and Training Unit, 2211 Park Towne Circle, Suite 4, Sacramento, CA 95825. 916-574-2528. Although this publication is geared toward general industry, the ideas presented are easily transferable to agriculture.

Blueprinttwo: The Ergonomics Manual. 1990. Published by Comprehensive Loss Management, Inc., Minneapolis. This 40-page guide is designed for supervisors and managers to help employees prevent cumulative trauma disorders. It discusses the risk factors of cumulative trauma disorders and specific prevention strategies, including 80 illustrations. Copies can be obtained for \$4.95 each by calling 800-279-0288 ext. 122.

Videos

Listen to Your Body: Safe Lifting, Pushing and Pulling, English/Spanish, 1992, 30 minutes. Illustrates how back injuries occur and demonstrates safe lifting techniques. Made by the University of Florida. Available from: Safety Coordinator, Department of Agricultural and Biosystems Engineering, University of Arizona, Shantz Bldg, Room 403, PO Box 210038, Tucson, AZ 85721-0038. Materials are sent on a loan basis. User agrees to return materials on or before a scheduled date and to pay return shipping costs. Please request materials as far in advance as possible. Telephone requests accepted at 520-626-3134.

Ergonomic Programs That Work, English, 1998, 21 minutes. Shows how several companies resolved ergonomic problems in their workplaces, resulting in higher productivity and fewer lost workdays. Can be borrowed from U.S. Department of Labor, Occupational Safety and Health Administration, Office of Public Affairs, Room N3647, 200 Constitution Avenue, Washington, DC 20210. 202-693-1999. osha.videos@osha-slc.gov. Duplication of tape for further use is permitted. Can be bought from NTIS (National Technical Information Service) for \$55 +\$5 shipping and handling. Call 800-553-6847. Order #AVA20258-VNB1INA.

NIOSH Lifting Equation

This equation is a simple way to determine a recommended weight limit for specific tasks. The equation plugs in factors such as the height from the floor that the object is picked up from, the distance the object is moved, and the frequency of lifts.

The equation and instructions on how to use it are available from the NTIS (National Technical Information Service). Ask for PB94-176930; cost is \$12.00 plus \$4.00 handling. Write to NTIS, U.S. Dept of Commerce, Technology Administration, Springfield, VA 22161. Call 703-487-4650 or fax 703-321-8547.

Cooperative Extension Services

Contact your local county agricultural extension office. This is usually listed under county government in the phone book, but sometimes under U.S. government (agriculture) or state government.

You can also contact the extension services at land-grant universities. These are the big public universities in each state; in Michigan, for example, Michigan State University. Call the university's agriculture department. For a complete list of university extension services, go to <http://www.reeusda.gov/1700/statepartners/usa.htm> (click on your state). Or contact CSREES (Cooperative State Research, Education, and Extension Service), an agency of the U. S. Department of Agriculture, at USDA, Washington, DC 20250-0900. Phone 202-720-3029. Fax 202-690-0289.

The OSHA Consultation Program

OSHA's free consultation service is delivered by state governments using well-trained professional staff. Consultants can assist you in recognizing potential workplace hazards on your farm and suggest approaches or options for eliminating these hazards. Primarily for smaller, high-hazard businesses with 10 or more employees, this service is completely separate from OSHA enforcement. No citations are issued and no penalties are proposed.

Setting it up: Your phone call or letter sets the machinery in motion. The consultant will discuss your needs with you and set up a visit date. OSHA encourages a complete review of your work environment; however, you may limit the visit to a specific problem, such as ergonomics.

The walk-through: Together, you and the consultant will examine occupational safety and health conditions at your farm. OSHA encourages employee participation in the walk-through. Talking with employees helps the consultant identify and judge any hazards; it also allows the consultant to provide limited informal training, upon request.

The consultant will do an appraisal of all mechanical and environmental hazards and physical work practices, or will look just at the specific operations you designate. You will learn not only what you need to improve, but also what you are doing right. Hazard abatement dates are determined by you and the consultant.

The On-Site Consultant Will:

- Help you recognize occupational safety and health hazards in your workplace.
- Suggest general approaches or options for solving a safety or health workplace problem.
- Identify kinds of help available if you need further assistance.
- Provide you a written report summarizing findings.
- Assist you in developing or improving your safety and health management system.
- Provide occupational health and safety formal training for you and your employees.

The On-Site Consultant Will Not:

- Issue citations or propose penalties for violations of OSHA standards.
- Report possible violations to OSHA enforcement staff.
- Guarantee that your workplace will “pass” an OSHA inspection.

For more information about the OSHA Consultation Program, you can contact the Consultation Project in your state (directory follows) or go to the OSHA web site at www.osha.gov.

ALABAMA
Safe State Program, University of
Alabama
205-348-3033

ALASKA
Consultation Section,
ADOL/AKOSH
907-269-4957

ARIZONA
Consultation and Training, Industrial
Commission, Division of
Occupational Safety and Health
602-542-5795

ARKANSAS
OSHA Consultation, Department of
Labor
501-682-4522

CALIFORNIA
CAL/OSHA Consultation Service,
Department of Industrial
Relations
415-703-5270

COLORADO
Colorado State University,
Occupational Safety and Health
Section
970-491-6151

CONNECTICUT
Department of Labor, Division of
Occupational Safety and Health
860-566-4550

DELAWARE
Department of Labor, Division of
Industrial Affairs, Occupational
Safety and Health
302-761-8219

DISTRICT OF COLUMBIA
Program available only for employ-
ers within the District of
Columbia
DC Department of Employment
Services, Office of Occupational
Safety and Health
202-576-6339

FLORIDA
Department of Labor and
Employment Security, 7(c)(1)
Onsite Consultation Program,
Division of Safety
850-922-8955

GEORGIA
Georgia Institute of Technology,
7(c)(1) Onsite Consultation
Program
404-894-2643

GUAM
OSHA Onsite Consultation,
Department of Labor
671-475-0136

HAWAII
Consultation and Training Branch,
Department of Labor and
Industrial Relations
808-586-9100

IDAHO
Boise State University, Department
of Health, Safety and Health
Consultation Program
208-426-3283

ILLINOIS
Onsite Consultation, Industrial
Service Division, Department of
Commerce and Community
Affairs
312-814-2337

INDIANA
Bureau of Safety, Education and
Training, Division of Labor
317-232-2688

IOWA
7(c)(1) Consultation Program,
Bureau of Labor
515-965-7162

KANSAS
7(c)(1) Consultation Program,
Department of Human Resources
785-296-7476

KENTUCKY
Labor Cabinet, Division of
Education and Training
502-564-6895

LOUISIANA
7(c)(1) Consultation Program,
Department of Labor
225-342-9601

MAINE
Division of Industrial Safety, Bureau
of Labor Standards, Workplace
Safety and Health Division
207-624-6460

MARYLAND
MOSH Consultation Services
410-880-4970

MASSACHUSETTS
Division of Occupational Safety and
Health, Department of Work
force Development
617-727-3982

MICHIGAN (Health) Occupational Health Division 517-322-6823	NORTH CAROLINA Bureau of Consultative Services, Department of Labor, OSHA Division 919-807-2905	UTAH Labor Commission, Workplace Safety and Health, Consultation Services 801-530-6901
MICHIGAN (Safety) Department of Consumer and Industry Services 517-322-1809	NORTH DAKOTA Division of Environmental Engineering 701-328-5188	VERMONT Division of Occupational Safety and Health, Department of Labor and Industry 802-828-2765
MINNESOTA Department of Labor and Industry, Consultation Division 612-297-2393	OHIO Bureau of Employment Services, Division of Onsite Consultation 614-644-2246	VIRGINIA Department of Labor and Industry, Occupational Safety and Health, Training and Consultation 804-786-6359
MISSISSIPPI Mississippi State University, Center for Safety and Health 601-987-3981	OKLAHOMA Department of Labor, OSHA Division 405-528-1500	VIRGIN ISLANDS Division of Occupational Safety and Health, Department of Labor 340-772-1315
MISSOURI Onsite Consultation Program, Division of Labor Standards, Department of Labor and Industrial Relations 573-751-3403	OREGON Oregon OSHA, Department of Consumer and Business Services 503-378-3272	WASHINGTON Department of Labor and Industries, Division of Industrial Safety and Health 360-902-5638
MONTANA Department of Labor and Industry, Bureau of Safety 406-444-6418	PENNSYLVANIA Indiana University of Pennsylvania 724-357-2396	WEST VIRGINIA Department of Labor 304-558-7890
NEBRASKA Division of Safety and Labor Standards, Department of Labor 402-471-4717	PUERTO RICO Occupational Safety and Health Office, Department of Labor and Human Resources 787-754-2171	WISCONSIN (Health) Department of Health and Human Services, Division of Public Health, Section of Occupational Health 608-266-9383
NEVADA Safety Consultation and Training Section, Division of Industrial Relations, Department of Business and Industry 702-486-9140	RHODE ISLAND OSH Consultation Program, Division of Occupational Health and Radiation Control, Department of Health 401-222-2438	WISCONSIN (Safety) Department of Commerce, Division of Marketing, Advocacy and Technology Development, Bureau of Manufacturing and Assessment 262-523-3044 or 800-947-0553
NEW HAMPSHIRE Department of Health and Human Services 603-271-2024	SOUTH CAROLINA Department of Labor, Licensing and Regulation 803-734-9614	WYOMING Department of Employment, Workers' Safety and Compensation Division 307-777-7786
NEW JERSEY Department of Labor, Division of Public Safety and Occupational Safety and Health 609-292-3923	SOUTH DAKOTA Engineering Extension, Onsite Technical Division, South Dakota State University 605-688-4101	
NEW MEXICO Environment Department, Occupational Health and Safety Bureau 505-827-4230	TENNESSEE OSHA Consultation Services Division, Department of Labor 615-741-7036	
NEW YORK Division of Safety and Health 518-457-2238	TEXAS Workers' Health and Safety Division, Workers' Compensation Commission 512-804-4640 OSHCON Request Line: 800-687-7080	